

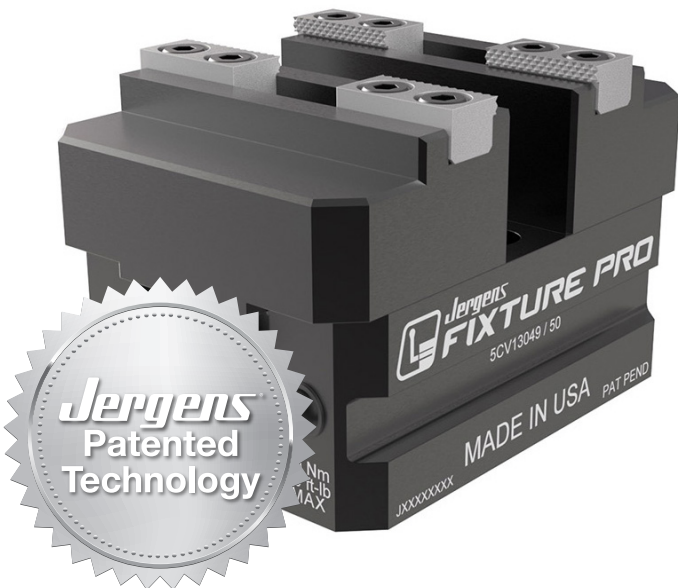

WISE UPGRADE

**Trade your old vise for credit/discount towards a
NEW Jergens 5-Axis Self-Centering Vise**



**JAW LIFT?
ELIMINATE DOVETAILING!
RECENTER YOUR VISE ONSITE!
QUICK-CHANGE JAWS!
UP TO 20% SAVINGS!**

HOW IT WORKS:

Submit your name, company, contact information, your current vise issue(s), as well as a photo of the vise(s) you would like to trade.

After reviewing your submission, a representative from the Jergens team will discuss your issue(s) and current setup.

With this information, they will help match you with the best equivalent from our 5-Axis Self-Centering Vise line!
See reverse side for product information.

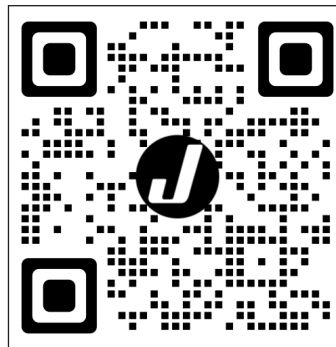

Scan QR Code to submit via form!

Questions?

workholding@jergensinc.com
1-877-426-2504

DISTRIBUTED BY:





FIXTURE-PRO® SELF-CENTERING VISE LINE

Clamping Force: 3,500 lbs. at 50 foot lbs.

Alternate jaw types are available in aluminum soft jaws, hardened step jaws, steel soft jaws or insert jaws.

75mm Self-Centering Vise

Available in 100mm or 160mm lengths

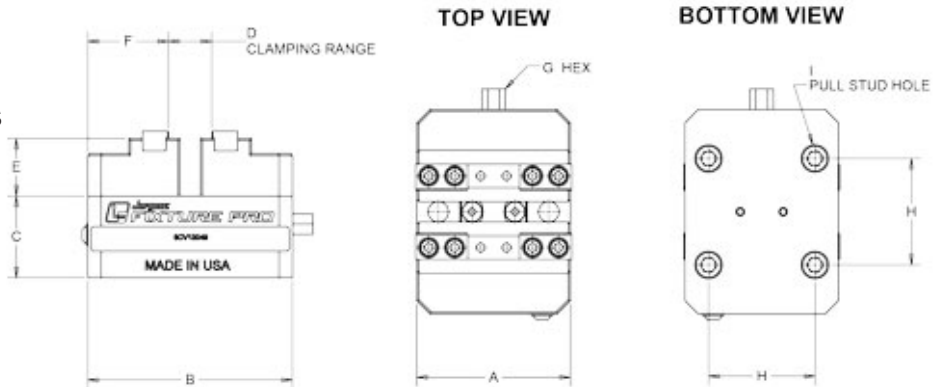

Part Number	A (mm)	B (mm)	C (mm)	D (mm)	E (mm)	F (mm)	G (mm)	H (mm)	Pull Stud Part Number	Pull Stud Included	Weight (kg)
5CV13049-IN	75	100	40	12-85	28	39.5	10	52	QL-200800	No	3.1
5CV13051-IN	75	160	40	12-145	28	39.5	10	52	QL-200800	No	4.0

130mm Self-Centering Vise

Available in 160mm or 250mm lengths

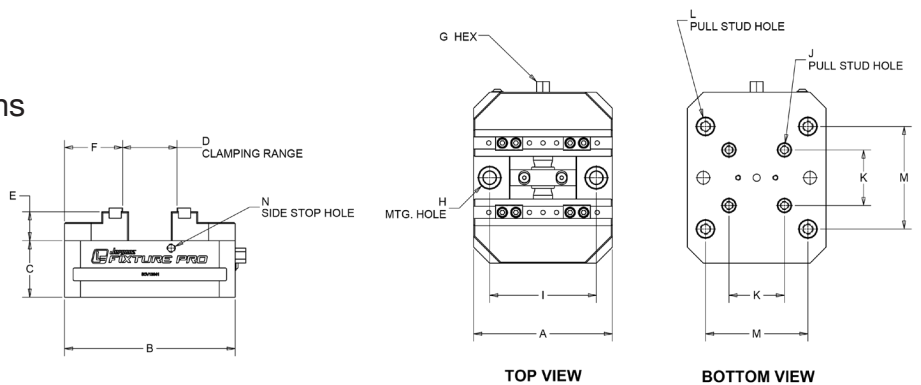

Part Number	A (mm)	B (mm)	C (mm)	D (mm)	E (mm)	F (mm)	G (mm)	H	I (mm)	J (mm)	K (mm)	Pull Stud Part Number	M (mm)	Pull Stud Included	N	Weight (kg)
5CV13041-IN	130	160	53	12-150	27	54	12	12mm QLS	100	QL-200800	52	QL-200805	96	No	M8x1.25	7.4
5CV13045-IN	130	250	53	12-240	27	54	12	12mm QLS	100	QL-200800	52	QL-200805	96	No	M8x1.25	10.2

Soft Jaw Sets

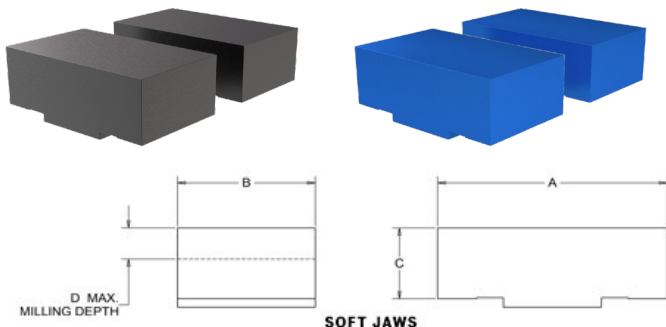

Part Number	Vise Size	A (mm)	B (mm)	C (mm)	D (mm)	Material
5CV13049-ASJ	75	75	45	25	11	Aluminum
5CV13049-ASJ-50	75	75	45	50	36	Aluminum
5CV13049-SSJ	75	75	45	25	11	Steel
5CV13049-SSJ-50	75	75	45	50	36	Steel
5CV13041-ASJ	130	130	74	26	12	Aluminum
5CV13041-ASJ-50	130	130	74	50	36	Aluminum
5CV13041-SSJ	130	130	74	26	12	Steel
5CV13041-SSJ-50	130	130	74	50	36	Steel

